



Digitized Automation for a Changing World

Delta Advanced IIoT Controller AX-5 Series

Delta Advanced IIoT Controller AX-5 Series

Ultra Slim | Scalable | Boundless

Industry 4.0 has accelerated automation in a variety of production scenarios. Smart manufacturing requires faster data updates and system expandability, which has led to rising demands for higher-performance computing, speedier changeover, and flexible configuration.

Delta's Advanced IIoT Controller AX-5 Series is suitable for production line equipment, capable of simultaneously controlling servo drives, AC motors, remote I/O modules, and other mechanical motions. The AX-5 Series adopts a 4-core processor, which not only meets the precise axis control needs of production lines, but also supports industrial network communication protocols such as EtherNet/IP, PROFINET, EtherCAT, as well as third-party Wi-Fi and Bluetooth ([Wi-Fi and Bluetooth available in Q3 2025](#)), making it easy to integrate different production line information into production management systems. The system utilizes a high-speed 100 Mbps EtherCAT bus and Hot Connect, ensuring high-precision synchronization control and real-time I/O updates. In addition to PLCopen standard motion control commands, Delta's exclusive motion commands for servo drives and AC motors provide an excellent single development environment, reducing programming time. The 12 mm ultra-thin I/O design minimizes cabinet size, while the independent I/O power supply simplifies wiring, delivering highly stable system operation and flexible I/O module expansion. The AX-5 Series is equipped with user-friendly IoT functions, compatible with FTP and Type-C USB for convenient remote maintenance and on-site immediate programming and debugging.

The AX-5 Series integrates with a wide range of communication protocols, and offers a convenient integrated development environment, helping equipment manufacturers reduce hardware, service costs, and development time.



Table of Contents

• Product Architecture	01
• Features	03
• Advanced Control Solution (AX Controller / DIADesigner-AX)	13
• Models and Specifications	15
• Dimensions	27
• Ordering Information	29

Product Architecture

Standard EtherCAT Motion Control System

Supports EtherCAT and DIADesigner-AX programming software, providing high-speed I/O bus and IIoT applications

- Uses a 4-core processor, balancing motion control and communication performance
- Offers EtherCAT motion control with various axes options
- The shortest execution time for basic instructions is 1ns; Min. synchronization time is up to 32 axes/1ms
- Supports the new generation of AX-5 Series ultra-thin power supplies, digital I/O, analog I/O, and temperature expansion modules
- Adopts 100 Mbps EtherCAT high-speed I/O system bus
- Built-in communication protocols include EtherCAT, CANOpen, PROFINET, Modbus, EtherNet/IP, OPCUA server, MQTT, FTP, and more
- Provides USB Type-A interface for connecting third-party Wi-Fi or Bluetooth adapters (Wi-Fi and Bluetooth available in Q3 2025)
- Complies with IEC 61131-3 standards with SoftPLC and SoftMotion development environment

AX-5 EtherCAT I/O System

- Supports EtherCAT Distributed Clock (DC) for high-precision synchronous control
- Allows online EtherCAT updates for I/O firmware
- I/O overvoltage / overcurrent protection and diagnosis
- Supports EtherCAT Hot Connect configuration
- SIL3 level functional safety CPU and I/O based on FSoE (available in Q3 2025)

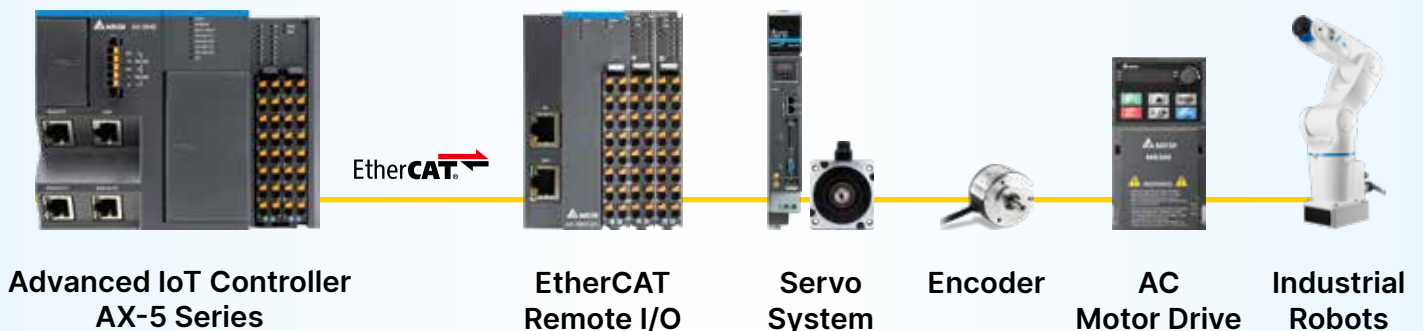

CPU & Appearance

Built-in RJ-45 Port

- CANopen: DS301 Master
- EtherCAT: 16/32/64 axes (supports up to 4,096 slaves)

USB Type A (Host: Master Device)

Supports third-party Wi-Fi or Bluetooth adapters (available in Q3 2025)

Built-in Serial Port

Modbus: RS-232/RS-485

Arm Cortex 4-Core Processor

- Basic Command: 1 ns
- Synchronization Performance: 32 axes @ 1ms
- Program Capacity: 64 MB
- Data Capacity: 32/64 MB



RUN/STOP Switch

SD Card Slot

- Firmware updates
- Project backup or restore

Power Terminals

- Unit Power
- I/O Power

I/O Terminals

- 12 Digital Inputs (DI)
- 4 Digital Outputs (DO)

GbE Communication Ports:

2 independent IPs

- EtherNet/IP
- PROFINET
- Modbus TCP

USB Type C

(Slave: Peripheral Device)

USB PD (Power Delivery) 5V 3A

Features

High-Performance Computing

To fulfill IIoT's demand of heterogeneous platform compatibility, complex programming, data collection and analytics, the AX-5 Series adopts a high-performance all-in-one Arm Cortex 4-core processor.

- **Arm Cortex 4-Core Processor**

Multitasking processing with 4-core processor ensures that communication does not affect motion control and computing performance.

The diagram features a central image of an AX-5 Series industrial controller. To its left, a list of supported protocols is shown: EtherCAT, EtherNet/IP, Modbus, CANopen, and PROFINET. To the right, a graph plots 'Quantity of Cores' on the vertical axis against 'Performance' on the horizontal axis. Three processor icons are shown: a single-core processor (x1), a dual-core processor (x2), and a four-core processor (x4) labeled 'AX-5', which is enclosed in a blue box to indicate its superior performance.

- **Built-in Various Communication Protocols**

Meets the needs of advanced equipment with reduced extra module costs, while enabling high performance axes control and data exchange.

This diagram illustrates two communication scenarios. The top scenario, labeled 'High-Speed Data Exchange', shows an AX-5 controller connected via a red line to a DOP (Digital Operator Panel) and another AX-5 controller, with 'EtherNet/IP' and 'Modbus TCP' protocols indicated. The bottom scenario, labeled 'Remote I/O Solution', shows two AX-5 controllers connected via yellow and purple lines to various industrial components including a motor, a sensor, and a robotic arm. The protocols 'EtherCAT' and 'PROFINET' are associated with these connections.

• **High Synchronization Accuracy EtherCAT Bus**

Significantly improves I/O update speed.

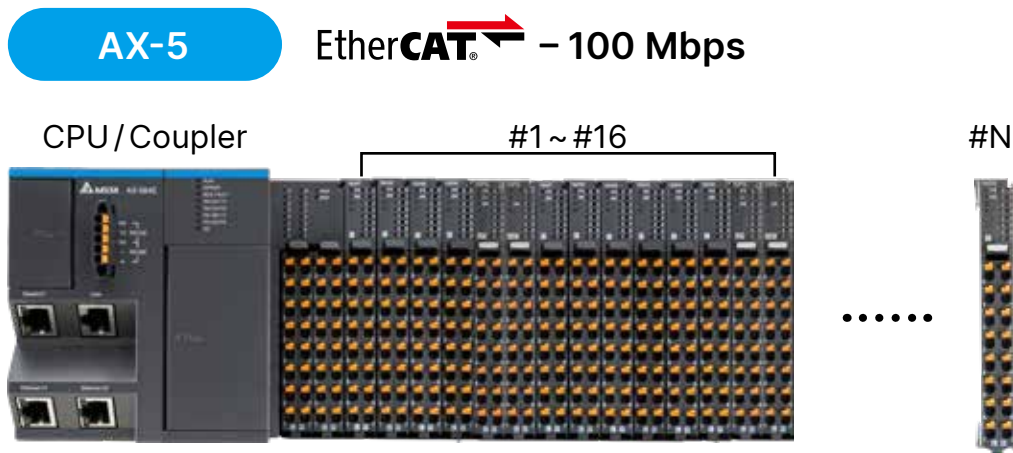

*Note: Power supply module can be installed on the right side of AX-5's I/O module, expandable to Max. 4,096 pcs

Utilizes a 100Mbps EtherCAT system bus between couplers and I/O modules, ensuring real time I/O updates and precise synchronization.

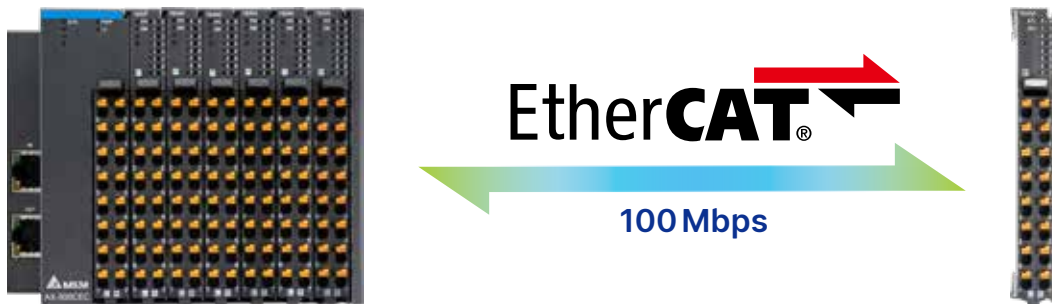

Features

PLCopen and Delta-Defined Instructions

The AX-5 Series offers a diverse range of motion control solutions, including Delta-defined DMC motion control commands, PLC open MC standard commands, E-CAM editor, and position planning tools. By using commands based on PLC open along with Delta-defined commands, training and technical support costs can be reduced.

- Supports single-axis / multi-axis, PLCopen add-ons, stop functions, and CAM controllers
- Additional POU for different tasks, such as monitoring dynamic data or following errors, operating CAM and CAM controllers
- Integrated graphical CAM editor provides rich configuration options
- Supports virtual and logical axes
- Integrated drivers for pulse train and EtherCAT protocols
- Configures drivers as standard field devices

DMC Delta-Defined Instructions

※ For detailed information on Delta-specific DMC_ and PLCopen MC_ standard motion control commands and examples, please refer to the 'AX Series Motion Control Command Manual / Chapter 2: Motion Control Commands.

Motion Control Commands

- **DMC_TorqueControl:** Torque Control
- **DMC_VelocityControl:** Velocity Control
- **DMC_MoveLinearAbsolute:** The absolute linear interpolation for a specified absolute position
- **DMC_MoveLinearRelative:** The relative linear interpolation
- **DMC_MoveCircularAbsolute:** Performs circular or helical interpolation for a specified absolute target position
- **DMC_MoveCircularRelative:** Performs circular or helical interpolation for a specified relative target position
- **DMC_GroupStop:** Decelerates the group axes to a stop
- **DMC_GroupHalt:** Decelerates the axis group in motion to a pause
- **DMC_Home_P:** Drives the pulse axis to perform homing in the set mode
- **DMC_MoveVelocityStopByPos:** Controls an axis to stop at a specified position after a period of motion

Administrative Instruction Commands

- **DMC_GroupEnable:** Switches GroupDisable to GroupStandby
- **DMC_GroupDisable:** Sets the state of an axis group to GroupDisable
- **DMC_GroupReadStatus:** Reads the state of an axis group
- **DMC_GroupReadError:** Reads axis group errors
- **DMC_GroupReset:** Resets an axis group which is in GroupErrorstop state

Administrative Instruction Commands

- **DMC_CamReadTappetStatus:** Reads the status of multiple tappets
- **DMC_CamReadTappetValue:** Reads the data of one single tappet
- **DMC_CamWriteTappetValue:** Modifies the tappet data for the specified existing track
- **DMC_CamAddTappet:** Adds a new tappet track at the end of the tappet table
- **DMC_CamDeleteTappet:** Deletes the specified tappet track
- **DMC_CamReadPoint:** Reads the data of one single cam point
- **DMC_CamWritePoint:** Writes the data of one single cam point
- **DMC_ChangeMechanismGearRation:** Modifies the ratio between user units and pulses, axis type and user units per rotation of the rotary axis
- **DMC_ReadMotionState:** Reads the behavior state of the axis in motion
- **DMC_AxesObserve:** Monitors the deviation between the master axis position and slave axis position
- **DMC_PositionLag:** Sets the allowed range of lag error
- **DMC_SetTorqueLimit:** Sets the Max. torque of an axis
- **DMC_SetSoftwareLimit:** Enables, disables, and sets the upper and lower software limits
- **DMC_CamKeyPointWrite:** Allows writing key cam points by selecting a curve type and generating corresponding cam curve based on related parameters
- **DMC_TouchProbeCyclically:** Continuously records the captured position of an axis

Positioning Axis Commands

- **MC_Power_DML:** Enables, disables and immediately stops the specified axis
- **MC_Stop_DML:** Decelerates the specified axis to a stop
- **MC_Reset_DML:** Clears axis-related errors
- **MC_Halt_DML:** Halts an axis in a controllable way
- **MC_Home_DML:** Controls the axis to perform the homing operation
- **MC_MoveAbsolute_DML:** Controls the specified axis to move to the specified absolute target position based on the specified motion behavior
- **MC_MoveRelative_DML:** Controls the specified axis to move to the specified relative target position according to the specified motion behavior
- **MC_MoveVelocity_DML:** Performs velocity control on an axis in the position mode with a specified behavior and a constant velocity
- **MC_WriteBoolParameter_DML:** Writes a Boolean value in the specified parameter
- **MC_ReadBoolParameter_DML:** Reads the Boolean value of a specified parameter
- **MC_WriteParameter_DML:** Writes a value in the specified parameter
- **MC_ReadParameter_DML:** Reads the value of a specified parameter
- **MC_ReadStatus_DML:** Reads the state of a specified axis
- **MC_TorqueControl_DML:** Controls the torque by using the torque control mode of the applied servo drive
- **MC_ChangeAxisConfig_DML:** Modifies basic axis settings
- **MC_ReinitDrive_DML:** Reinitializes the specified axis

Features

Ultra Slim I/O Module

- 12 mm ultra-thin design reduces cabinet costs
- Removable terminal and clip design for easy installation and efficient wiring
- 100 Mbps EtherCAT bus for high-precision synchronization and real-time updates
- Independent I/O power wiring enhances signal stability and reduces downtime risk; module expansion only requires additional power wiring
- Over-voltage and current protection with diagnostics ensures stable system operation
- HotConnect for rapid configuration and process switching based on production lines

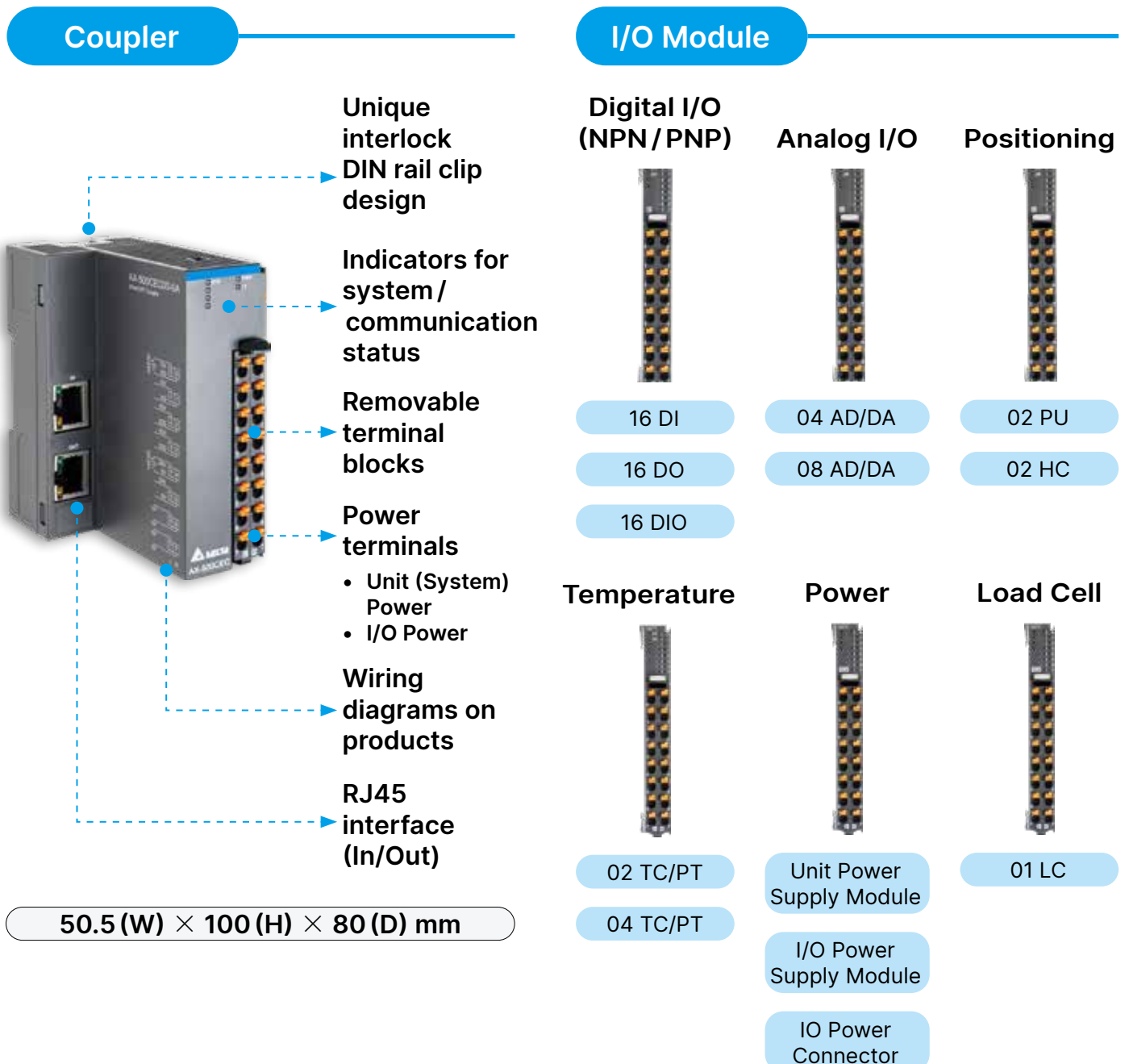

Simple Installation

The unique DIN rail clip design entails a simple 2-step process for module removal and installation, saving commissioning time and maintenance effort.

- **Fast Removal**

Step 1: Release either the upper or bottom clip so that both clips can be released from the DIN rail.

Step 2: Remove the module from the front. There's no need to adjust adjacent modules.

- **Simple Installation**

Step 1: Press both clips.

Step 2: Push the module until you hear a "click" sound. Both clips will be secured on the DIN rail.



Features

Highly-Efficient System Bus

Supports EtherCAT Hot Connect

Hot Connect allows slaves to be easily removed or added flexibly in the EtherCAT network, enabling fast configuration. Users can maintain the same project and apply changes to systems with different scales.

Hot Connect can adapt to different configuration changes according to Hot Connect groups defined by EtherCAT Master

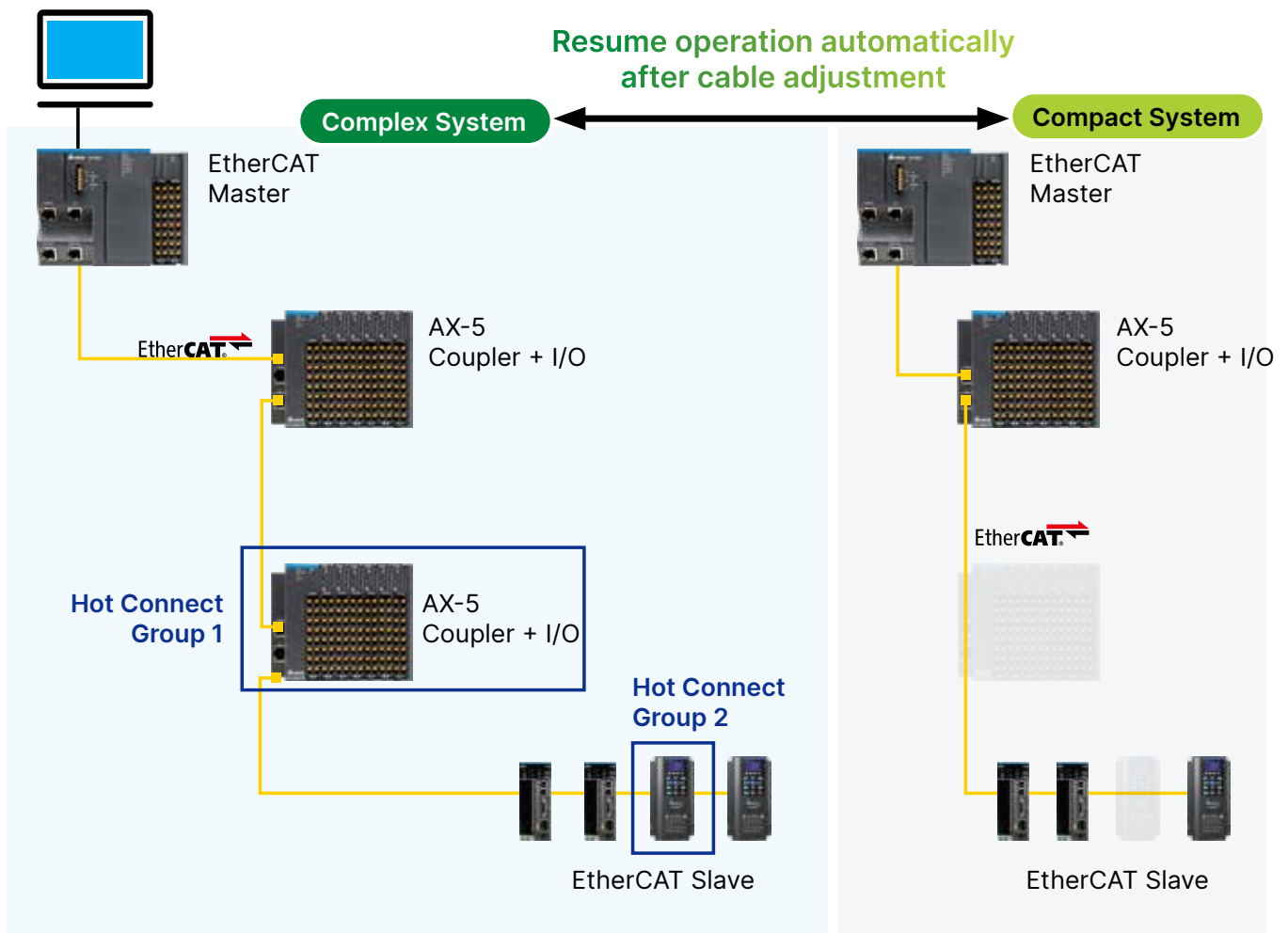

Supports EtherCAT Distributed Clock (DC) Function

The EtherCAT DC function is the key to achieving precise synchronization control between master and slaves.

*Note: DC can reach as fast as 0.5ms

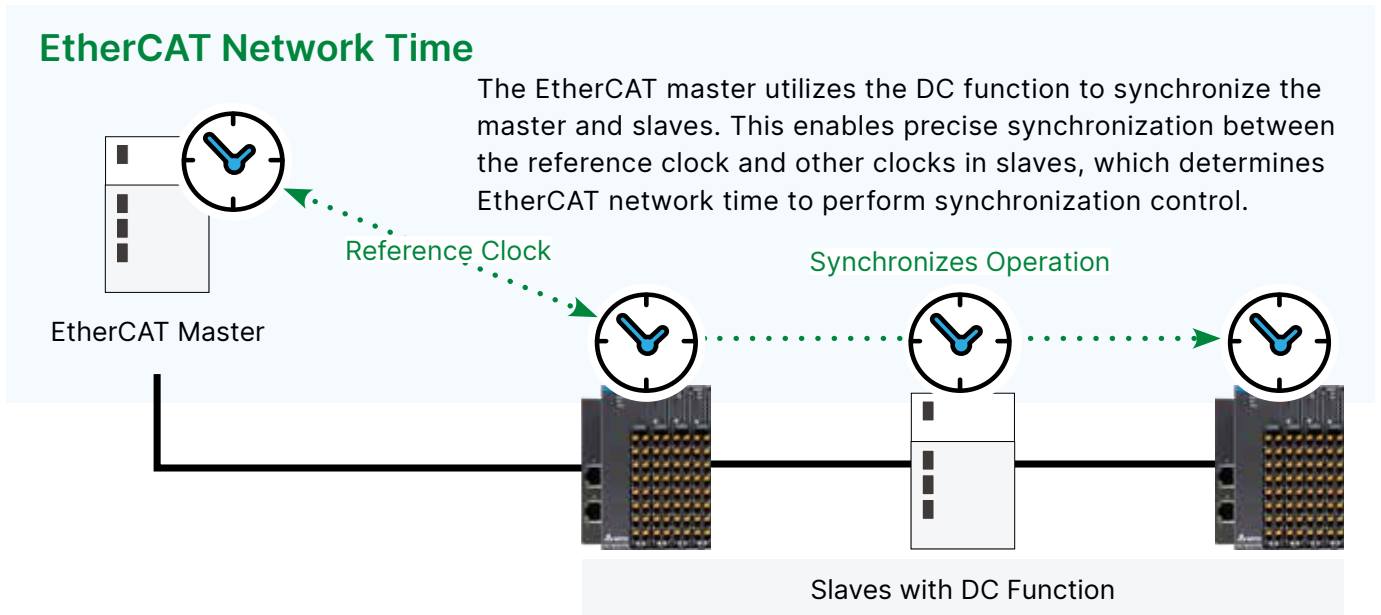

Grouped I/O Signal and Power Management

Supports expansion of I/O modules with System Power Supply and I/O Power Supply Modules. The I/O Power Supply Module can be used to separate the I/O in different groups for stable I/O signals. In all, this feature speeds up I/O error troubleshooting and reduces system downtime.

*Note: The current consumption required for each I/O varies. It can be configured through HWCONFIG in DIADesigner-AX, indicating when it is necessary to reconfigure the power module.

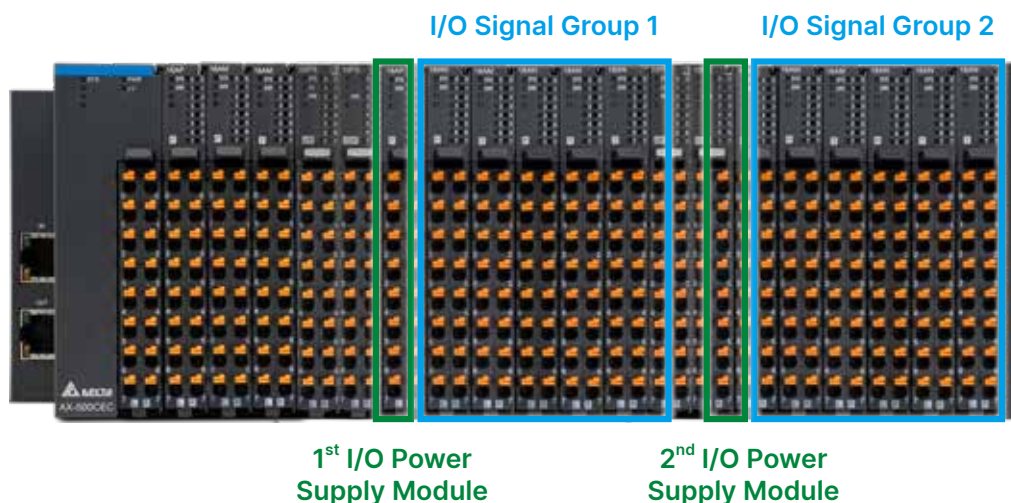

Features

IoT Functions

Supports Third-Party Wi-Fi/Bluetooth (available in Q3 2025)

Wireless connection of field devices reduces equipment debugging and configuration time

USB Type A (Host : Main Device)

Supports third-party Wi-Fi and Bluetooth



Wi-Fi



Wireless Equipment Maintenance

- Firmware update
- Hardware config. change
- Program update
- Monitoring and troubleshooting

Bluetooth

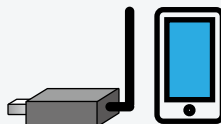

Mobile Point Monitoring

- Historical value graphs
- Current value



FTP

Remote maintenance reduces on-site customer service cost

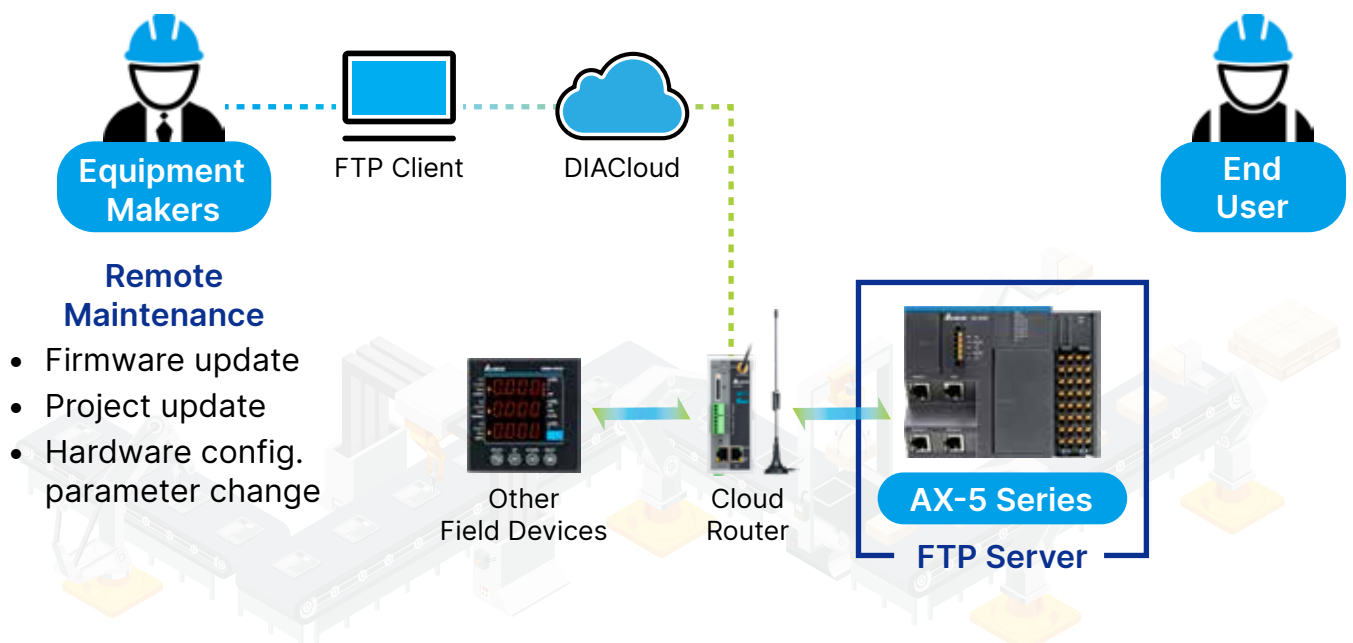

Programming with USB Type C

Directly update projects via Type C to enhance work efficiency

- The CPU can operate without an external power supply

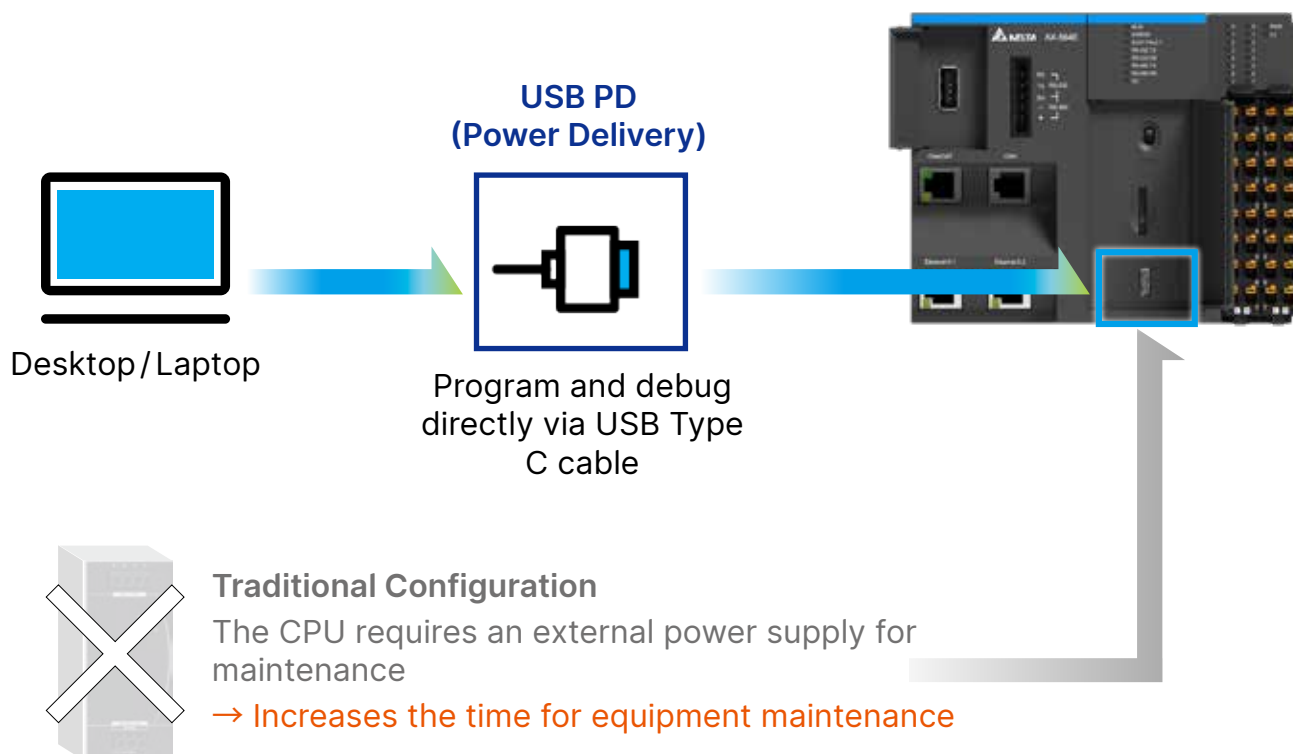

Advanced Control Solution

Motion Control Solution

Flexibly choose between integrating DIAStudio programming software (DIADesigner-AX, DIAScreen, DIASelector) or AX motion control solutions based on project needs. This allows you to not only shorten the time required to build systems and equipment but also significantly reduce labor costs.







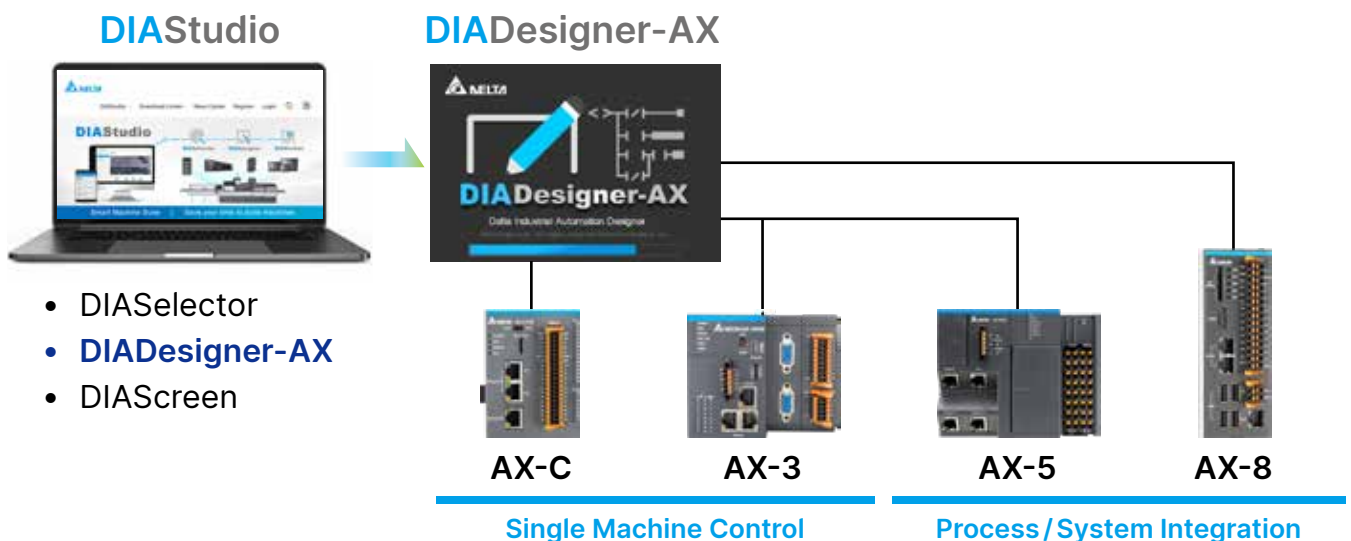

DIAStudio is Delta's next-generation software integration platform, combining Delta PLCs, HMIs, Delta inverters, servo motor drives, and related industrial automation products.

DIAStudio Integrated and Scalable Design

- **Highly Integrated Single Platform:** Develop once, use across the entire line, and reduce development time and costs
- **Standardized Programming:** Compliant with IEC 61131-3 standards, DIAStudio provides a standardized programming and controller development platform
- **Supports Secondary Development:** Customizable functions and elements to meet specific needs
- **DIADesigner-AX:** Supports various controllers (PC-Based or PLC-Based) and operating systems including Windows, VxWorks, and Linux
- **Supports EtherCAT High-Speed Communication Bus:** Efficient, precise, and smooth motion control, enhancing productivity
- **HMI Variable Sharing:** Quickly and easily configure shared variables, reducing programming time
- **Versatile Applications:** Suitable for industries such as industrial robotics, woodworking, printing, packaging, electronic assembly and more



AX Motion Control Solution

Motion Control Programming Software			
	Control System	Standalone	PLC-Based
<p>AX-8 AX-C</p> 		<p>AX-3 AX-5</p> 	<p>DOP-100</p> 
Field Device	AC Servo Drive	Remote I/O Module	AC Motor Drive
	<p>ASDA-A2-E ASDA-A3-E ASDA-B3-E</p> 	<p>R1-EC R2-EC</p>  <p>RTU-ECAT R2-EC0004D0</p>  <p>(EtherCAT Remote I/O)</p>	<p>C2000 Plus</p>  <p>MH300 MS300</p> 



Models and Specifications

CPU Modules

Item	AX-516EB OMB1T/P	AX-532EB OMB1T/P	AX-564EB OMB1T/P	AX-564ELB OMB1T/P
Language	LD, ST, CFC, SFC, FBD, IL			
Execution Time	Ld Instruction	1 ns		
	Arithmetic Instruction (Lreal Data Type)	7 ns		
Program Capacity	64 MB			32 MB
Variable Memory	Retainive	1MB device memory (%M), 0.5MB retain, 512KB persist		
	Non-Retainive	64 MB		
Max. Number of Slaves	4,096			
Built-In IO	12 DI (80 kHz) / 4 DO (80 kHz)			
DO Output	NPN / PNP			
Pulse Out	Open collector: 4 Groups 80 kHz; A/B phase, CW/CCW, Pulse/Direction: 2 Groups 50 kHz			
High-Speed Counter	Open collector, CW/CCW, Pulse/Direction: 4 Groups 80 kHz; A/B, A/B/Zphase, A/B (Quadruple frequency), A/B/Z (Quadruple frequency) phase : 4 Groups 50 kHz			
Built-In Communication Port	Ethernet x 2 (Independent IP), CANopen x 1, EtherCAT x 1, RS-485 x 1, RS-232 x 1, USB-Type A x 1, USB-Type C x 1, Micro SD (SDXC, 64 GB max/UHS-I)			
Communication Protocol	ARP, IP, TCP, UDP, Modbus TCP, Modbus ASCII/RTU, EtherNet/IP, OPCUA (Server), PROFINET RT (Class A), EtherCAT (Class B), CANopen (DS301 v4.02)			
Ethernet Max. Number of Connections	Modbus TCP (Client+Server): 128 EtherNet/IP (CIP_Explicit Message): 12 EtherNet/IP (CIP_IO Connection) - Scanner: 128 Adapter: 32			
PROFINET	Max. IO device: 64; Max. Data Length per Transmission - Input: 1,440 bytes, Output: 1,440 bytes			
CANopen	Max. TPDO/RPDO: 256 (Max. data size: 1000 bytes) *Up to 8 TPDO/RPDO for every slave			
Max. Number of Controlled Axes (Synchronous Axis + Positioning Axis + Virtual Axis)	32	64	128	80
Max. Number of Synchronous Axes (Time Synchronization)	16 (@1ms)	32 (@1ms)	64 (@2ms)	8 (@0.5ms)
Max. Number of Positioning Axes	32	64	128	64
Max. Number of Virtual Axes	32	64	128	80
Max. Number of Pulse Out Axes	2			
Max. Number of Axes for Linear Interpolation Axis Control	6			
Max. Number of Axes for Arc Interpolation Axis Control	2			
Max. Number of Axes for Helical Interpolation Axis Control	3			
Max. Number of Axes Groups	8	16	32	4
Real-Time Clock	Year, Month, Date, Hour, Minute, Second, Week Data retainable for 30 days (at 25°C/77°F environment)			
	Maximum deviation in seconds per month -20°C/-4°F: -117 seconds 25°C/77°F: 52 seconds 55°C/131°F: -127 seconds			

CPU Electrical

Item	AX-516EB OMB1T/P	AX-532EB OMB1T/P	AX-564EB OMB1T/P	AX-564ELB OMB1T/P
Unit Power Input Voltage / Power	24 V _{DC} (-15% ~ 20%) / 27 W			
I/O Power Input Voltage / Power	24 V _{DC} (-15% ~ 20%) / under 240 W , depending on external power output			
Max. Unit Power Supply	2 A (10 W)			
Max. Power Consumption (UV/UG)	0.5 A (12 W)			
Max. Power Consumption (I/O Power)	24 V _{DC} / 2 A			
Min. Power Consumption (I/O Power)	10 mA			
Built-In Digital Input 12 Points (24 V _{DC} Signals)	Input Form	NPN / PNP		
	Input Current	2.5 mA TYP. (24 V _{DC}), constant current		
	Max. Response Time ON / OFF	6.25 μs		
	Max. Input Frequency	80 kHz		
	Over-Voltage / Overcurrent Protection	Current limiting		
Built-In Digital Output 4 Points	Output Form	NPN / PNP		
	Voltage	24 V _{DC} (-15% / +20%)		
	Resistance	0.5 A / Point		
	Leakage Current	Less than 0.1 mA		
	Max. Response Time ON / OFF	6.25 μs		
	Max. Output Frequency	80 kHz		
Weight	560 g			
Dimensions (mm)	125 (W) x 100 (H) x 105 (D)			

Power Module

Item	AX-502PS11-0A	
External Connector	Spring-clamp terminal block (16 terminals)	
Electrical	Unit Power Input Voltage/Power	24 V _{DC} (-15% ~ 20%) / 14 W
	Max. Unit Power Supply	2 A (10 W)
	Max. I/O Power Supply	N/A
Current Capacity for Spring-Clamp Terminal Block	Less than 5 A / terminal; less than 10 A / module	
Max. Power Consumption for Module (UV/UG)	42 mA (1 W)	
Min. Power Consumption (I/O Power)	No power consumed	
Isolation Method	Between unit power and external power: no isolation Between unit power and I/O power: 500 V _{AC} (20 MΩ min.)	
Input Power Protection (UV/UG)	Voltage / current protection, under-voltage warning	
Unit Power Protection	Voltage / current protection	
Dimensions (mm)	12 (W) x 100 (H) x 80 (D)	
Weight	75 g	

Models and Specifications

I/O Power Supply Modules

Item	AX-510 PS12-0A	AX-516 PC10-0A	AX-516 PC20-0A	AX-516 PC30-0A	AX-514 PC40-0A
External Connector	Spring-clamp terminal block (16 terminals)				
Input Voltage / Power (Unit Power)	24 V _{DC} (-15% ~ 20%) / under 240 W, depending on external power output			N/A	
Max. Unit Power Supply	N/A				
Max. I/O Power Supply	Under 10A (240 W), depending on external power output			N/A	
Current Capacity for Spring-Clamp Terminal Block	Less than 5 A /terminal; less than 10 A /module				
Max. Power Consumption for Module (I/O Power)	1 mA (0.024 W)			N/A	
Min. Power Consumption (Unit Power)	No power consumed			N/A	
Isolation Method	Between I/O power and external power: no isolation Between unit power and I/O power: 500 V _{AC} (20 MΩ min.)				
Dimensions (mm)	12 (W) x 100 (H) x 80 (D)				
Weight	60 g				

EtherCAT Coupler

Item	AX-500CEC00-0A	
External Connectors	One spring-clamp terminal block (16 terminals) RJ45 x 2 IN: EtherCAT input port / OUT: EtherCAT output port	
Electrical	Unit Power Input Voltage / Power	24 V _{DC} (-15% ~ 20%) / 16 W
	I/O Power Input Voltage / Power	24 V _{DC} (-15% ~ 20%) / under 240 W, depending on external power output
	Max. Unit Power Supply	2 A (10 W)
	Max. I/O Power Supply	Under 10A (240 W), depending on external power output
Current Capacity For Spring-Clamp Terminal Block	Less than 5 A per terminal	
Max. Power Consumption (UV/UG)	50 mA (1.2 W)	
Isolation Method	Between unit power and external power: no isolation Between I/O power and external power: no isolation Between unit power and I/O power: 500 V _{AC} (20 MΩ min.) EtherCAT port: 500 V _{AC}	
Input Power Protection (UV/UG)	Voltage / current protection, under-voltage warning	
Unit Power Protection	Voltage / current protection	
Dimensions (mm)	50.5 (W) x 100 (H) x 80 (D)	
Weight	165 g	

PROFINET Coupler

Item		AX-500CPN00-0A
External Connectors		One spring-clamp terminal block (16 terminals) RJ45 x 2 IN: PROFINET input port/OUT: PROFINET output port
Electrical	Unit Power Input Voltage/Power	24 V _{DC} (-15% ~ 20%) / 20 W
	I/O Power Input Voltage/Power	24 V _{DC} (-15% ~ 20%) / under 240 W, depending on external power output
	Max. Unit Power Supply	2 A (10 W)
	Max. I/O Power Supply	Under 10 A (240 W), depending on external power output
Current Capacity For Spring-Clamp Terminal Block		Less than 5 A per terminal
Max. Power Consumption (UV/UG)		200 mA (4.8 W)
Isolation Method		Between unit power and external power: no isolation Between I/O power and external power: no isolation Between unit power and I/O power: 500 V _{AC} (20 MΩ min.) PROFINET port: 500 V _{AC}
Input Power Protection (UV/UG)		Voltage/current protection, under-voltage warning
Unit Power Protection		Voltage/current protection
Dimensions (mm)		61 (W) x 100 (H) x 80 (D)
Weight		185 g

Digital Input Modules

Item	AX-516AM10-0A	AX-516AM20-0A
Input Points	16	
External Connector Type	Spring-clamp terminal block (16 terminals)	
I/O Refresh Modes	1. Free Run mode 2. DC mode	
I/O Form	NPN	PNP
Max. ON/OFF Response Time	150 μs / 150 μs	
Max. Power Consumption (Unit Power)	200 mA (1 W)	
Max. Power Consumption (I/O Power)	24 V _{DC} / 40 mA	
Min. Power Consumption (I/O Power)	No power consumed	
Over Voltage Protection / Over Current Protection	Current limiting	
Filter Function	Input filter time: 0 ~ 255 ms; 3 ms (default)	
Isolation Method	1. Between unit power and external power: no isolation 2. Between digital signal and internal signal: 500 V _{AC} 3. Between channels: no isolation	
Dimensions (mm)	12 (W) x 100 (H) x 80 (D)	
Weight	69 g	

Models and Specifications

Digital Output Modules

Item	AX-516AN01-0A	AX-516AN02-0A
Output Points	16	
External Connector Type	Spring-clamp terminal block (16 terminals)	
I/O Refresh Modes	1. Free Run mode 2. DC mode	
I/O Form	NPN	PNP
Max. ON/OFF Response Time	150 μ s / 150 μ s	
Max. Power Consumption (Unit Power)	200 mA (1W)	
Max. Power Consumption (I/O Power)	24 V _{DC} / 2 A x 1	24 V _{DC} / 8 A
Min. Power Consumption (I/O Power)	10 mA	
Over Voltage Protection / Over Current Protection	Yes	
Isolation method	1. Between unit power and external power: no isolation 2. Between digital signal and internal signal: 500 V _{AC} 3. Between channels: no isolation	
Dimensions (mm)	12 (W) x 100 (H) x 80 (D)	
Weight	70 g	

Digital Input / Output Modules

Item	AX-516AP11-0A	AX-516AP22-0A
Input/Output Points	8DI/8DO	
External Connector Type	Spring-clamp terminal block (16 terminals)	
I/O Refresh Modes	1. Free Run mode 2. DC mode	
I/O Form - Input/Output	NPN/NPN	PNP/PNP
Max. ON/OFF Response Time	150 μ s / 150 μ s	
Max. Power Consumption (Unit Power)	200 mA (1W)	
Max. Power Consumption (I/O Power)	24 V _{DC} / 1 A	24 V _{DC} / 4 A
Min. Power Consumption (I/O Power)	10 mA	
Over Voltage Protection / Over Current Protection	Current limiting	
Filter Function	Firmware filtering time: 0 ~ 255 ms; 3 ms (default)	
Isolation Method	1. Between unit power and external power: no isolation 2. Between digital signal and internal signal: 500 V _{AC} 3. Between channels: no isolation	
Dimensions (mm)	12 (W) x 100 (H) x 80 (D)	
Weight	70 g	71 g

Analog Input Modules

Item	AX-504AD10-0A	AX-504AD20-0A	AX-508AD10-0A	AX-508AD20-0A
Input Points	4		8	
External Connector Type	Spring-clamp terminal block (16 terminals)			
I/O Refresh Modes	1. Free Run mode 2. DC mode			
Input Form	Differential input			
Input Range	-10 ~ 10 V	-20 ~ 20 mA	-10 ~ 10 V	-20 ~ 20 mA
Resolution	-10 ~ 10 V: 16 Bits -5 ~ 5 V: 15 Bits	-20 ~ 20 mA: 16 Bits 0 ~ 20 mA: 15 Bits	-10 ~ 10 V: 16 Bits -5 ~ 5 V: 15 Bits	-20 ~ 20 mA: 16 Bits 0 ~ 20 mA: 15 Bits
Conversion Time	100 μs / 4 points		200 μs / 8 points	
Max. Power Consumption (Unit Power)	Less than 400 mA (2 W)		Less than 440 mA (2.2 W)	
Min. Power Consumption (I/O Power)	No power consumed			
Over Voltage Protection / Over Current Protection	N/A			
Filter Function	AVG / FIR / IIR			
Isolation Method	1. Between unit power and external power: no isolation 2. Between digital power and analog power: 500 V _{AC} 3. Between digital signal and analog signal: 500 V _{AC} 4. Between analog channels: no isolation			
Dimensions (mm)	12 (W) x 100 (H) x 80 (D)			
Weight	73 g	73 g	73 g	74 g

Analog Output Modules

Item	AX-504DA01-0A	AX-504DA02-0A	AX-508DA01-0A
Output Points	4		8
External Connector Type	Spring-clamp terminal block (16 terminals)		
I/O Refresh Modes	1. Free Run mode 2. DC mode		
Input Range	-10 ~ 10 V	0 ~ 20 mA	-10 ~ 10 V
Resolution	-10 ~ 10 V: 16 Bits -5 ~ 5 V: 15 Bits	0 ~ 20 mA: 15 Bits	-10 ~ 10 V: 16 Bits -5 ~ 5 V: 15 Bits
Conversion Time	100 μs / 4 points		200 μs / 8 points
Max. Power Consumption (Unit Power)	Less than 500 mA (2.5 W)	Less than 640 mA (3.2 W)	
Min. Power Consumption (I/O Power)	No power consumed		
Over Voltage Protection / Over Current Protection	N/A		
Filter Function	N/A		
Isolation Method	1. Between unit power and external power: no isolation 2. Between digital power and analog power: 500 V _{AC} 3. Between digital signal and analog signal: 500 V _{AC} 4. Between analog channels: no isolation		
Dimensions (mm)	12 (W) x 100 (H) x 80 (D)		
Weight	73 g	74 g	

Models and Specifications

Thermocouple Temperature Modules

Item	AX-502TC10-0B	AX-504TC10-0B
Input Points	2	4
External Connector Type	Spring-clamp terminal block (16 terminals)	
I/O Refresh Modes	Free Run mode	
Input Form	Differential input	
Sensor Type	J, K, T, E, L, U, N, R, S, B, C (WRe5-26), PL II , ± 130 mV	
Connection Type	2-Wire	
Resolution	TC mode: 0.1°C/0.18°F x 1 ± 130 mV mode: 0.1 mV	
Conversion Time	100 ms/channel	
Cold Junction Compensation Error	± 1.2 °C	
Max. Power Consumption (Unit Power)	Less than 300 mA (1.5 W)	Less than 360 mA (1.8 W)
Min. Power Consumption (I/O Power)	No power consumed	
Over Voltage Protection / Over Current Protection	N/A	
Filter Function	AVG/FIR/IIR	
Isolation Method	<ol style="list-style-type: none"> 1. Between unit power and external power: no isolation 2. Between digital power and analog power: 500 V_{AC} 3. Between digital signal and analog signal: 500 V_{AC} 4. Between analog channels: no isolation 	
Dimensions (mm)	12 (W) x 100 (H) x 80 (D)	
Weight	70 g	

Resistance Temperature Modules

Item	AX-502PT10-0B	AX-504PT10-0B
Input Points	2	4
External Connector Type	Spring-clamp terminal block (16 terminals)	
I/O Refresh Modes	Free Run mode	
Input Form	Differential input	
Sensor Type	Pt100: DIN 43760-1980 JIS C1604-1989 , 100Ω 3850 PPM/°C Pt1000: DIN EN60751 , 1 kΩ 3850 PPM/°C Ni100/Ni1000: DIN 43760 0 ~ 300Ω	
Connection Type	2/3/4-Wire	
Resolution	0.001°C/0.0018°F x 1	
Conversion Time	100 ms/channel	
Temperature Measurement Accuracy	±0.3%: 25°C (F.S.) ±0.5%: 0 ~ 60°C (F.S.) ±1%: -20 ~ 0°C (F.S.)	
Max. Power Consumption (Unit Power)	Less than 360 mA (1.8 W)	Less than 400 mA (2 W)
Min. Power Consumption (I/O Power)	No power consumed	
Over Voltage Protection/ Over Current Protection	N/A	
Filter Function	AVG/FIR/IIR	
Isolation Method	1. Between unit power and external power: no isolation 2. Between digital power and analog power: 500 V _{AC} 3. Between digital signal and analog signal: 500 V _{AC} 4. Between analog channels: no isolation	
Dimensions (mm)	12 (W) x 100 (H) x 80 (D)	
Weight	70 g	

Models and Specifications

Positioning Modules

Item	AX-502PU01-0A
Number of Axes	2
External Connector Type	Spring-clamp terminal block (16 terminals)
I/O Refresh Modes	1. Free Run mode 2. DC
Motion Functions	Position control: Absolute positioning, relative positioning Velocity control: Constant speed control, variable speed control Synchronized control: E-Cam, E-Gear Auxiliary function: Homing, Immediate Stop and Smooth Stop Manual operation: JOG
Digital Input (NPN)	Input current: 2.5 mA TYP. (DC 24 V) ON voltage/ON current: 11 ~ 30 V (EN 61131-2, type 3) OFF voltage/OFF current: -3 ~ 5 V (EN 61131-2, type 3) Max. ON/OFF response time: I0 ~ I5: 20 μs / 40 μs I6 ~ I9: 1 μs / 2 μs
Digital Output (NPN)	Load voltage: 24 V _{DC} (-15% ~ 20%) Max. load current: 30 mA / point Max. surge current: 0.5 A / point, 10 ms Max. frequency: 500 kHz Max. ON/OFF response time: 1 μs max. / 2 μs max.
Max. Cable Length	3 m max.
Max. Power Consumption (UV, UG)	Less than 300 mA (1.5 W)
Min. Power Consumption (I/O Power)	Less than 10 mA
Digital Input - Over Voltage Protection / Over Current Protection	Current limiting Digital filter (2.5 kV _{AC})
Digital Output	Over Voltage Protection / Over Current Protection
Signal Insulation	Digital isolator (2.5 kV _{AC})
Dimensions (mm)	12 (W) x 100 (H) x 80 (D)
Weight	70 g

Item	AX-502HC10-0A
Number of Channels	2
External Connector Type	Spring-clamp terminal block (16 terminals)
I/O Refresh Modes	1. Free Run mode 2. DC
Counter Functions	Pulse input method: Phase differential pulse (multiplication x4) Counter range: -2147483648 ~ 2147483647 Counter type: Ring counter Counter controls: Counter reset, counter preset Latch function: 2 external input latches and 1 internal latch for each channel Measurements: Pulse rate measurement
Digital Input (NPN)	Input current: 2.5 mA TYP. (DC 24 V) ON voltage/ON current 11 ~ 30 V (EN 61131-2, type 3) OFF voltage/OFF current -3 ~ 5 V (EN 61131-2, type 3) Max. frequency: 2 MHz (500 kHz x 4) Max. ON/OFF response time: 1 μs / 2 μs
Digital Output (NPN)	Load voltage: 24 VDC (-15 % ~ 20 %) Max. load: current 30 mA / point Max. surge current: 0.5 A / point, 10 ms Max. ON/OFF response time: 1 μs max. / 2 μs max.
Max. Cable Length	3 m max.
Max. Power Consumption (UV, UG)	Less than 300 mA (1.5 W)
Min. Power Consumption (I/O Power)	Less than 10 mA
Digital input - Over Voltage Protection / Over Current Protection	Current limiting Digital filter (2.5 kV _{AC})
Digital Output	Over Voltage Protection / Over Current Protection
Signal Insulation	Digital filter (2.5 kV _{AC})
Dimensions (mm)	12 (W) x 100 (H) x 80 (D)
Weight	70 g

Models and Specifications

Load Cell Module

Item	AX-501LC10-0A
Input Point	1
External Connector Type	Spring-clamp terminal block (16 terminals)
I/O Refresh Modes	1. Free Run mode 2. DC mode
Characteristic Value Range	1~80 mV/V
Input Signal Range	± 400 mV
Max. Conversion Range	$\pm 102\%$
Allowable Load	$> 50\Omega$
Load Cell Excitation Voltage	$5V_{DC} \pm 10\%$
Sensor Type	4-Wire/6-Wire Load Cell Sensor
Resolution	24-bit
Accuracy	25°C: $\pm 0.01\%$ (F.S.)*1 -20~60°C: $\pm 0.04\%$ (F.S.)*1 Gain drift: ± 50 ppm/°C Zero drift: ± 2 μ V/°C
Conversion Time	500 μ s/point
Max. Power Consumption (Unit Power)	Less than 400 mA (2W)
Min. Power Consumption (I/O Power)	No power consumed
Over Voltage Protection / Over Current Protection	N/A
Filter Function	Low Pass Filter / AVG
Isolation Method	1. Between unit power and external power: no isolation 2. Between digital power and analog power: 500 V _{AC} 3. Between digital signal and analog signal: 500 V _{AC}
Dimensions (Mm)	12 (W) x 100 (H) x 80 (D)
Weight	70 g

Electrical and Environmental Specifications

Item	Specificaitons
Insulation	Designed in accordance with IEC/EN 61131-2, IEC/EN 61010-1 and IEC/EN 61010-2-201
DC Input Power Supply	20.4V to 28.8V (24V, -15% to +20%) In accordance with IEC/EN 61131-2 SELV/PELV circuit 24V _{DC} power supply is recommended
Pollution Degree	2: in accordance with IEC/EN 61131-2 and IEC/EN 61010-2-201
Overtoltage Category	2: in accordance with IEC/EN 61131-2 and IEC/EN 61010-2-201
Protection Rating	IP20, in accordance with IEC 60529 <ul style="list-style-type: none"> • Protection against a probe or approximate size of a finger to make contact with hazardous parts • Protection against solid objects with a diameter greater than or equal to 12.5 mm • No protection against water ingress
Flammability Classifications	UL94V-0

Item	Specificaitons
Free Fall	≤ 1 m
Operating Temperature	-20 °C ~ +60 °C
Storage Temperature	-40 °C ~ +85 °C
Altitude	≤ 2,000 m
Atmospheric Pressure	1,100 hPa ~ 750 hPa (typical)
Operating Humidity	5 ~ 95%, non-condensing
Vibration Resistance	In accordance with IEC61131-2, IEC60068-2-6 (TESTFc) 5 to 8.4 Hz: 3.5 mm displacement 8.4 to 150 Hz: 10 m/s ² (1 g constant acceleration)
Shock Resistance	In accordance with IEC61131-2, IEC60068-2-6 (TESTFc) Shock Type: Half-Sine Shock Severity: 150 m/s ² (15g) peak, 11 ms duration

Dimensions

Unit: mm

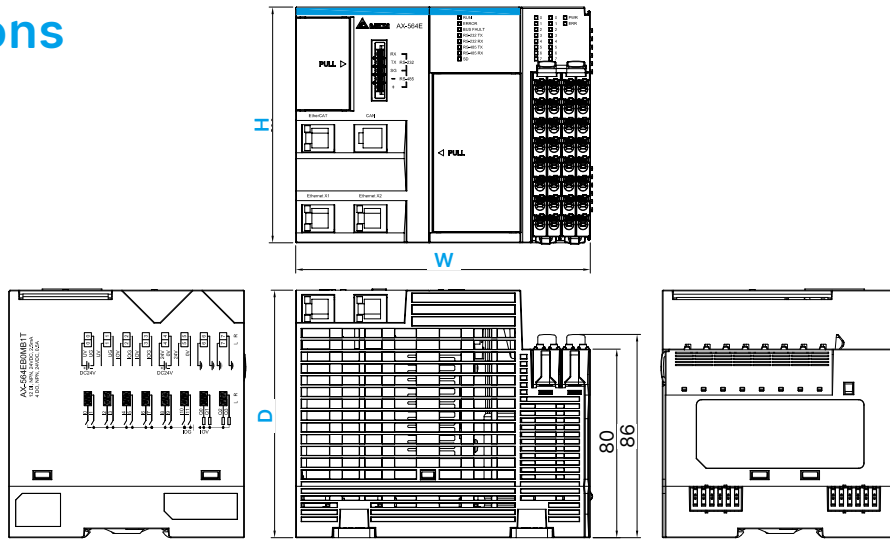

CPU Modules

	AX-516EBOMB1T/P	AX-532EBOMB1T/P	AX-564EBOMB1T/P	AX-564ELBOMB1T/P
W	125	125	125	125
H	100	100	100	100
D	105	105	105	105

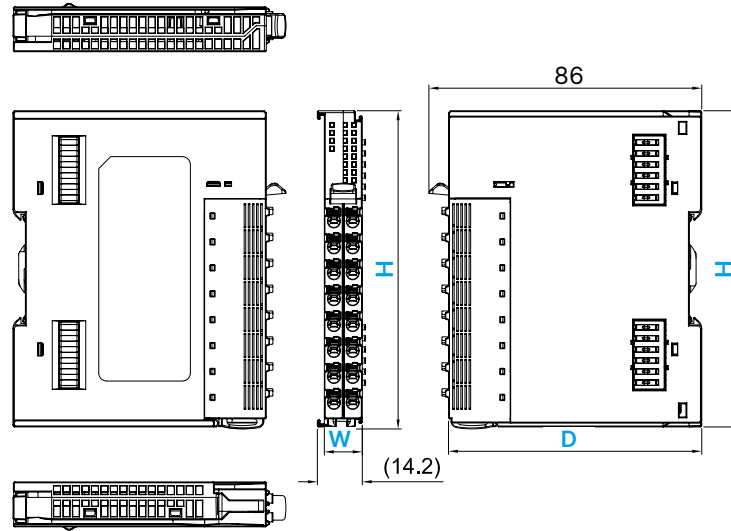

	Power Modules	Digital I/O Input Modules	Digital I/O Output Modules	Digital I/O Input / Output Modules	Analog I/O Input Modules	Analog I/O Output Modules
W	12	12	12	12	12	12
H	100	100	100	100	100	100
D	80	80	80	80	80	80

Unit: mm

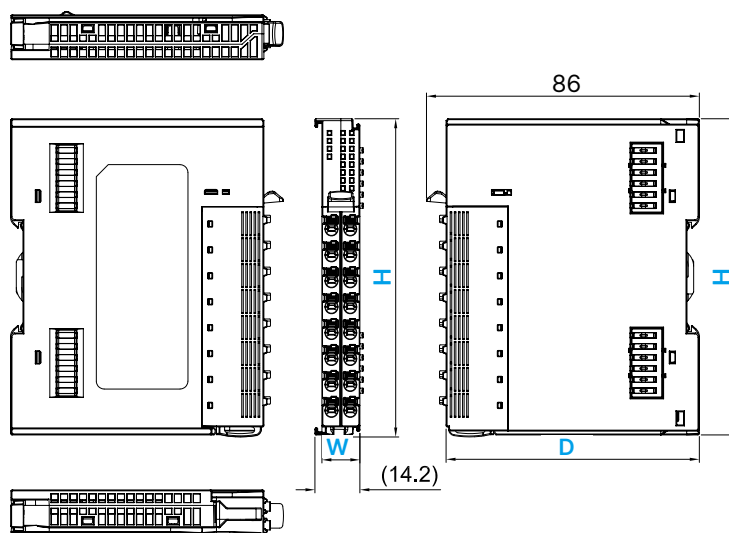

	Thermocouple Temperature Modules	Resistance Temperature Modules	Load Cell Module	Positioning Modules
	AX-502TC10-0B AX-504TC10-0B	AX-502PT10-0B AX-504PT10-0B	AX-501LC10-0A	AX-502HC10-0A AX-502PU01-0A
W	12	12	12	12
H	100	100	100	100
D	80	80	80	80

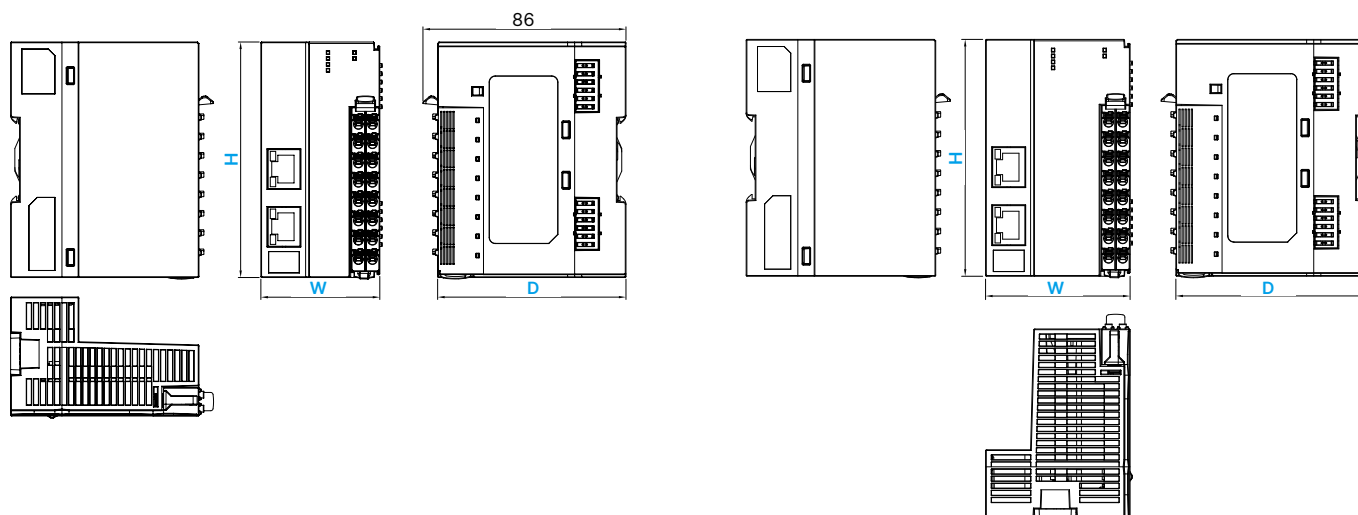



	EtherCAT Coupler
	AX-500CEC00-0A
W	50.5
H	100
D	80



	PROFINET Coupler
	AX-500CPN00-0A
W	61
H	100
D	80

Ordering Information

Power Modules

Item	Model Name	Description	Certificate
Unit Power Supply Module	AX-502PS11-0A	Unit power supply module - Unit power supply 24 V to 5 V, 2 A output	 
	AX-510PS12-0A	I/O power supply module - I/O power supply 24 V _{DC}	
I/O Power Supply / Connector Module	AX-516PC10-0A	IO power connector - 16 IOV	
	AX-516PC20-0A	IO power connector - 16 IOG	
	AX-516PC30-0A	IO power connector - 8 IOV / 8 IOG	
	AX-514PC40-0A	IO power connector - 14 PE	

CPU Modules

Item	Model Name	Description	Certificate
CPU	AX-564EB0MB1T	64-axis motion controller CPU module, 12 x DIs (80 kHz, NPN), 4 x DOs (80 kHz, NPN), 2 x Ethernet ports (independent IPs), 1 x CANopen port, 1 x EtherCAT port, 1 x RS-485 port, 1 x RS-232 port, 1 x USB-Type A port, 1 x USB-Type C, Micro SD interface, Program capacity: 64 MB, removable terminal blocks	 
	AX-564EB0MB1P	64-axis motion controller CPU module, 12 x DIs (80 kHz, PNP), 4 x DOs (80 kHz, PNP), 2 x Ethernet ports (independent IPs), 1 x CANopen port, 1 x EtherCAT port, 1 x RS-485 port, 1 x RS-232 port, 1 x USB-Type A port, 1 x USB-Type C, Micro SD interface, Program capacity: 64 MB, removable terminal blocks	
	AX-532EB0MB1T	32-axis motion controller CPU module, 12 x DIs (80 kHz, NPN), 4 x DOs (80 kHz, NPN), 2 x Ethernet ports (independent IPs), 1 x CANopen port, 1 x EtherCAT port, 1 x RS-485 port, 1 x RS-232 port, 1 x USB-Type A port, 1 x USB-Type C, Micro SD interface, Program capacity: 64 MB, removable terminal blocks	
	AX-532EB0MB1P	32-axis motion controller CPU module, 12 x DIs (80 kHz, PNP), 4 x DOs (80 kHz, PNP), 2 x Ethernet ports (independent IPs), 1 x CANopen port, 1 x EtherCAT port, 1 x RS-485 port, 1 x RS-232 port, 1 x USB-Type A port, 1 x USB-Type C, Micro SD interface, Program capacity: 64 MB, removable terminal blocks	
	AX-516EB0MB1T	16-axis motion controller CPU module, 12 x DIs (80 kHz, NPN), 4 x DOs (80 kHz, NPN), 2 x Ethernet ports (independent IPs), 1 x CANopen port, 1 x EtherCAT port, 1 x RS-485 port, 1 x RS-232 port, 1 x USB-Type A port, 1 x USB-Type C, Micro SD interface, Program capacity: 64 MB, removable terminal blocks	
	AX-516EB0MB1P	16-axis motion controller CPU module, 12 x DIs (80 kHz, PNP), 4 x DOs (80 kHz, PNP), 2 x Ethernet ports (independent IPs), 1 x CANopen port, 1 x EtherCAT port, 1 x RS-485 port, 1 x RS-232 port, 1 x USB-Type A port, 1 x USB-Type C, Micro SD interface, Program capacity: 64 MB, removable terminal blocks	
	AX-564ELB0MB1T	64-axis motion controller CPU module, 12 x DIs (80 kHz, NPN), 4 x DOs (80 kHz, NPN), 2 x Ethernet ports (independent IPs), 1 x CANopen port, 1 x EtherCAT port, 1 x RS-485 port, 1 x RS-232 port, 1 x USB-Type A port, 1 x USB-Type C, Micro SD interface, Program capacity: 32 MB, removable terminal blocks	
	AX-564ELB0MB1P	64-axis motion controller CPU module, 12 x DIs (80 kHz, PNP), 4 x DOs (80 kHz, PNP), 2 x Ethernet ports (independent IPs), 1 x CANopen port, 1 x EtherCAT port, 1 x RS-485 port, 1 x RS-232 port, 1 x USB-Type A port, 1 x USB-Type C, Micro SD interface, Program capacity: 32 MB, removable terminal blocks	

Digital I/O Modules

Item	Model Name	Description	Certificate
Digital I/O Modules	AX-516AM10-0A	16 DI, 24 V _{DC} , 2.5 mA, 1 ms, Source Input (NPN)	
	AX-516AM20-0A	16 DI, 24 V _{DC} , 2.5 mA, 1 ms, Sink Input (PNP)	
	AX-516AN01-0A	16 DO, 24 V _{DC} , 0.5 A, 1 ms, Sink Output (NPN)	
	AX-516AN02-0A	16 DO, 24 V _{DC} , 0.5 A, 1 ms, Source Output (PNP)	
	AX-516AP11-0A	8 DI, 24 V _{DC} , 2.5 mA, 1 ms, Source Input (NPN) 8 DO, 24 V _{DC} , 0.5 A, 1 ms, Sink Output (NPN)	
	AX-516AP22-0A	8 DI, 24 V _{DC} , 2.5 mA, 1 ms, Sink Input (PNP) 8 DO, 24 V _{DC} , 0.5 A, 1 ms, Source Output (PNP)	

Analog I/O Modules



Item	Model Name	Description	Certificate
Analog I/O Modules	AX-504AD10-0A	4 AI, ±10 V, 16 Bits, 100 μs	
	AX-508AD10-0A	8 AI, ±10 V, 16 Bits, 200 μs	
	AX-504AD20-0A	4 AI, ±20 mA, 16 Bits, 100 μs	
	AX-508AD20-0A	8 AI, ±20 mA, 16 Bits, 200 μs	
	AX-504DA01-0A	4 AO, ±10 V, 16 Bits, 100 μs	
	AX-508DA01-0A	8 AO, ±10 V, 16 Bits, 200 μs	
	AX-504DA02-0A	4 AO, 0 ~ 20 mA, 16 Bits, 100 μs	

Temperature Measurement Modules



Item	Model Name	Description	Certificate
Temperature Measurement Modules	AX-502TC10-0B	2 TC, J, K, T, E, L, U, N, R, S, B, C (WRe5-26), PLII, ± 130 mV, 24 Bits	
	AX-504TC10-0B	4 TC, J, K, T, E, L, U, N, R, S, B, C (WRe5-26), PLII, ± 130 mV, 24 Bits	
	AX-502PT10-0B	2 RTD, PT100, PT1000, Ni100, Ni1000, 0 ~ 300 Ω, 24 Bits	
	AX-504PT10-0B	4 RTD, PT100, PT1000, Ni100, Ni1000, 0 ~ 300 Ω, 24 Bits	

Ordering Information



Load Cell Module

Item	Model Name	Description	Certificate
Load Cell Module	AX-501LC10-0A	1 CH Load cell, 5 V	 

Positioning Modules

Item	Model Name	Description	Certificate
Positioning Modules	AX-502HC10-0A	2 CHs high-speed counter module, Open Collector, 500 kHz, Sourcing Input (NPN)	 
	AX-502PU01-0A	2 CHs positioning module, Open Collector, 500 kHz, Sinking Output (NPN)	

Couplers

Item	Model Name	Description	Certificate
Couplers	AX-500CEC00-0A	EtherCAT coupler	 
	AX-500CPN00-0A	PROFINET coupler	



Smarter. Greener. Together.

Industrial Automation Headquarters

Taiwan: Delta Electronics, Inc.

Taoyuan Technology Center
No.18, Xinglong Rd., Taoyuan District,
Taoyuan City 330477, Taiwan
TEL: +886-3-362-6301 / FAX: +886-3-371-6301

Asia

China: Delta Electronics (Shanghai) Co., Ltd.

No.182 Minyu Rd., Pudong Shanghai, P.R.C.
Post code : 201209
TEL: +86-21-6872-3988 / FAX: +86-21-6872-3996
Customer Service: 400-820-9595

Japan: Delta Electronics (Japan), Inc.

Industrial Automation Sales Department
2-1-14 Shibadaimon, Minato-ku
Tokyo, Japan 105-0012
TEL: +81-3-5733-1155 / FAX: +81-3-5733-1255

Korea: Delta Electronics (Korea), Inc.

1511, 219, Gasan Digital 1-Ro., Geumcheon-gu,
Seoul, 08501 South Korea
TEL: +82-2-515-5305 / FAX: +82-2-515-5302

Singapore: Delta Energy Systems (Singapore) Pte Ltd.

4 Kaki Bukit Avenue 1, #05-04, Singapore 417939
TEL: +65-6747-5155 / FAX: +65-6744-9228

India: Delta Electronics (India) Pvt. Ltd.

Plot No.43, Sector 35, HSIIDC Gurgaon,
PIN 122001, Haryana, India
TEL: +91-124-4874900 / FAX: +91-124-4874945

Thailand: Delta Electronics (Thailand) PCL.

909 Soi 9, Moo 4, Bangpoo Industrial Estate (E.P.Z),
Pattana 1 Rd., T.Phraksa, A.Muang,
Samutprakarn 10280, Thailand
TEL: +66-2709-2800 / FAX: +66-2709-2827

Australia: Delta Electronics (Australia) Pty Ltd.

Unit 2, Building A, 18-24 Ricketts Road,
Mount Waverley, Victoria 3149 Australia
Mail: IA.au@deltaww.com
TEL: +61-1300-335-823 / +61-3-9543-3720

Americas

USA: Delta Electronics (Americas) Ltd.

5101 Davis Drive, Research Triangle Park, NC 27709, U.S.A.
TEL: +1-919-767-3813

Brazil: Delta Electronics Brazil Ltd.

Estrada Velha Rio-São Paulo, 5300 Eugênio de
Melo - São José dos Campos CEP: 12247-004 - SP - Brazil
TEL: +55-12-3932-2300 / FAX: +55-12-3932-237

Mexico: Delta Electronics International Mexico S.A. de C.V.

Gustavo Baz No. 309 Edificio E PB 103
Colonia La Loma, CP 54060
Tlalnepantla, Estado de México
TEL: +52-55-3603-9200

EMEA

EMEA Headquarters: Delta Electronics (Netherlands) B.V.

Sales: Sales.IA.EMEA@deltaww.com
Marketing: Marketing.IA.EMEA@deltaww.com
Technical Support: iatechnicalsupport@deltaww.com
Customer Support: Customer-Support@deltaww.com
Service: Service.IA.emea@deltaww.com
TEL: +31(0)40 800 3900

BENELUX: Delta Electronics (Netherlands) B.V.

Automotive Campus 260, 5708 JZ Helmond, The Netherlands
Mail: Sales.IA.Benelux@deltaww.com
TEL: +31(0)40 800 3900

DACH: Delta Electronics (Netherlands) B.V.

Coesterweg 45, D-59494 Soest, Germany
Mail: Sales.IA.DACH@deltaww.com
TEL: +49 2921 987 238

France: Delta Electronics (France) S.A.

ZI du bois Challand 2, 15 rue des Pyrénées,
Lisses, 91090 Evry Cedex, France
Mail: Sales.IA.FR@deltaww.com
TEL: +33(0)1 69 77 82 60

Iberia: Delta Electronics Solutions (Spain) S.L.U

Ctra. De Villaverde a Vallecas, 265 1º Dcha Ed.
Hormigueras – P.I. de Vallecas 28031 Madrid
TEL: +34(0)91 223 74 20
Carrer Llacuna 166, 08018 Barcelona, Spain
Mail: Sales.IA.Iberia@deltaww.com

Italy: Delta Electronics (Italy) S.r.l.

Via Meda 2-22060 Novedrate(CO)
Piazza Grazioli 18 00186 Roma Italy
Mail: Sales.IA.Italy@deltaww.com
TEL: +39 039 8900365

Turkey: Delta Greentech Elektronik San. Ltd. Sti. (Turkey)

Şerifali Mah. Hendem Cad. Kule Sok. No:16-A
34775 Ümraniye – İstanbul
Mail: Sales.IA.Turkey@deltaww.com
TEL: + 90 216 499 9910

MEA: Eltek Dubai (Eltek MEA DMCC)

OFFICE 2504, 25th Floor, Saba Tower 1,
Jumeirah Lakes Towers, Dubai, UAE
Mail: Sales.IA.MEA@deltaww.com
TEL: +971(0)4 2690148